

**WIKING®**

# NEW ITEMS AUGUST 2015

## NEW CONTAINER WORLD

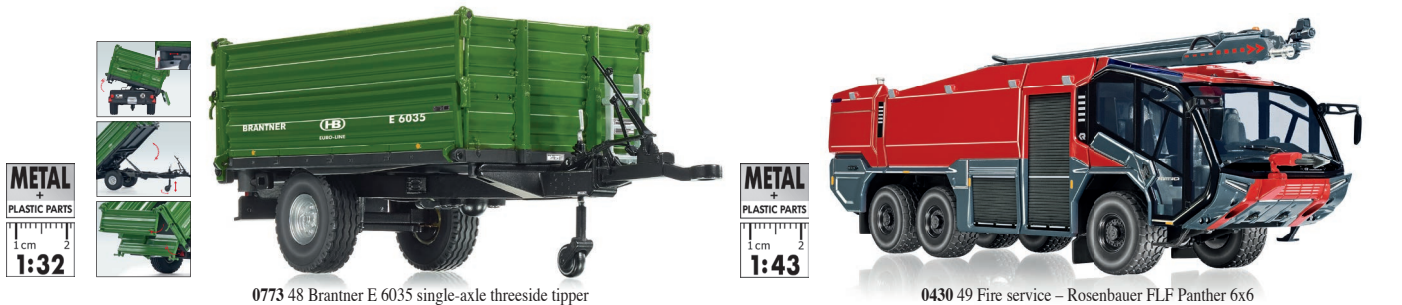

0773 48 Brantner E 6035 single-axle threeside tipper

0430 49 Fire service – Rosenbauer FLF Panther 6x6



0042 01 Emergency service – VW 1600 Variant

0513 19 Box semi-trailer (Henschel HS 14/16)

0149 23 Taxi – MB 190 D



0018 13 Accessories package – 40' container (NG)

0523 49 Container semi-truck (NG) (Scania)



0876 48 Steyr 80

0537 07 Curtain-sided semi-truck (MAN TGX Euro 6)

**W**IKING has made the true-to-scale 1:87 container world mobile, and long cherished collector's dreams come true. A Scania container semi-truck and matching set of accessories for the change of containers mark the beginning. The long-standing model makers, who began with the miniaturization of logistics boxes more than 50 years ago, have taken the most up-to-date prototypes of chassis and containers for the new models, which are made perfect by the exact and finely detailed printing. The MAN TGX Euro 6 is included among the new



0923 01 Land Rover – N-gauge 1:160



0934 03 Fire service  
VW Passat B6 – N-gauge 1:160

models. It carries forward the popular shipping theme of the „Mäuler“ company into the present day. Memories of times long past are

awakened with the Austria tractor Steyr 80 and the long-awaited Henschel HS 14/16 in the colors of the Hamburg-based shipping company. The latest generation of the Rosenbauer Panther 6x6 makes its debut in 1:43 scale. In the scale of 1:32, the Brantner E 6035 as single-axle threeside tipper promises lots of fun. The Land Rover is presented to N-gauge fans.

Wiking-Modellbau GmbH & Co. KG  
Schlittenbacher Str. 60  
58511 Lüdenscheid  
info@wiking.de · www.wiking.de

Subject to changes in colour and technical modifications



# MODEL UPGRADES AUGUST 2015

## SPORTY IN THE SUMMER



0820 04 Ford Taunus G73A with trailer



0797 16 VW T1 panel truck



1160 03 Electric cart with trailers (Still)



0890 03 Fendt Farmer 2S with front loader



0165 04 Porsche Carrera convertible



0205 47 Ford Mustang convertible



0230 01 MB C 111

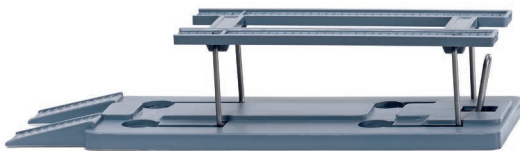

0850 98 Hydraulic platform



0421 01 Mobile crane (MB L 3500)



0624 02 Fire service - dumper truck (Magirus Deutz)



0433 03 High-sided flatbed truck (MB)

In 1:87 scale, a reunion takes place with such beautiful classics as the legendary Mercedes-Benz C 111 as well as the Mercedes-Benz L 3500 as service crane truck. The VW T1 appears in the former colors of the Henschel customer service. The Mercedes-Benz with a cube-shaped cabin and high-sided flatbed extends the range of the WIKING miniatures as does the

Ford Taunus G73A with trailer. For the first time, WIKING moves the last generation of Magirus Eckhauber into the program as dumper truck of the fire service. For the fans of farming, the Fendt Farmer 2S0 with front loader joins the show. Legendary WIKING milestones like the Still electric cart and the formerly innovative hydraulic platform have returned to the model range. The Ford

Mustang and Porsche Carrera radiate the flair of yesterday's and today's convertibles – modelmakers' summer passion in 1:87 scale!

Wiking-Modellbau GmbH & Co. KG  
Schlittenbacher Str. 60  
58511 Lüdenscheid  
info@wiking.de · www.wiking.de